

INTERPROVINCIAL CORROSION CONTROL COMPANY LIMITED *(Since 1957)*

930 SHELDON COURT, BURLINGTON, ONTARIO
Regional Offices: Calgary, Alberta & Montreal, Quebec
TEL: (905) 634-7751 CENTRAL FAX: (905) 333-4313
www.Rustrol.com

COR - CAP[®] ZINC ANODE CAP

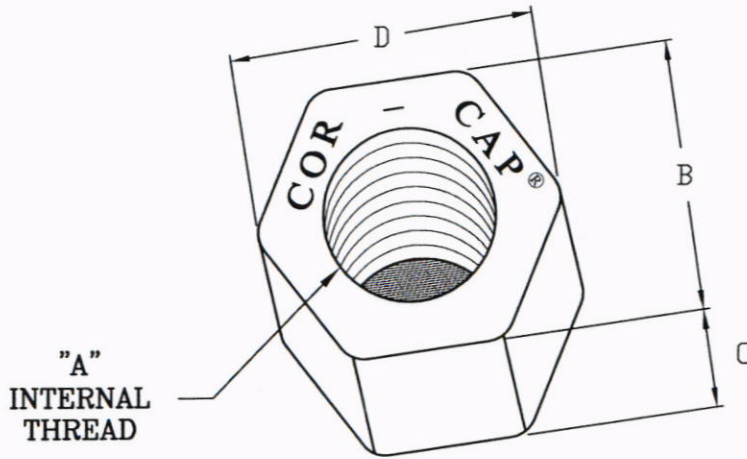

SELECTION CHART

PRODUCT CODE	DIMENSIONS							NOMINAL WEIGHT *	
	A	B		C		D		LBS	Kg
		INCHES	mm	INCHES	mm	INCHES	mm		
Cor-Cap [®] : ZC-500	1/2" x 13 UNC	1.50	38.10	0.98	24.90	1.69	42.95	0.38	0.15
Cor-Cap [®] : ZC-625	5/8" x 11 UNC	1.50	38.10	0.98	24.90	1.69	42.95	0.38	0.15
Cor-Cap [®] : ZC-750	3/4" x 10 UNC	1.50	38.10	0.98	24.90	1.69	42.95	0.38	0.15
Cor-Cap [®] : ZC-875	7/8" x 9 UNC	1.50	38.10	1.02	25.90	1.69	42.95	0.38	0.15
Cor-Cap [®] : ZC-1000	1" x 8 UNC	1.50	38.10	1.02	25.90	1.69	42.95	0.38	0.15
Cor-Cap [®] : ZC-1125	1 1/8" x 7 UNC	1.88	47.75	1.67	42.40	2.08	52.85	0.88	0.40
Cor-Cap [®] : ZC-1250	1 1/4" x 7 UNC	1.88	47.75	1.67	42.40	2.08	52.85	0.88	0.40

All dimensions are governed by Imperial Measurement

- FEATURES:**
- Manufactured to meet ASTM B418 *(latest edition)*
 - Ideal applications include: buried or submerged pipe fittings, dresser couplings, flange assemblies, hydrants, service boxes, heat exchangers, ballast tanks
 - Other sizes available on request

* Anode Nominal Weights tolerances: ± 2%, as stated above

This drawing is the property of Interprovincial Corrosion Control Company Ltd.
While published statements are believed to be accurate, they are offered as suggestions only.
Any use thereof is at the users independent discretion. No warranty or representation is intended.

REV.	DATE	DETAILED	CHECKED	DWG. NO.
0	JAN 14, 2010	MA	CO	PD-28
1	JAN 31, 2024	LCR	WBR	PD-28